



S800Na





CONTENTS

PRODUCT FEATURES	1
SPECIFICATION	1
ACOUSTIC CHARTS	2
AMPLIFICATION MODULE	6
INSTALLATION	7
DIMENSIONS	7
LIMITED WARRANTY	8

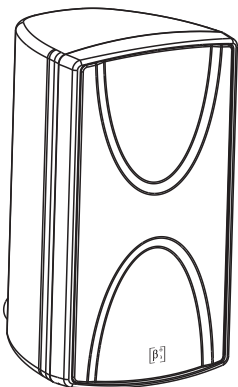

S800Na

Product Features

S800Na is compact dual eight inch active full range plastic speaker. The whole cabinet volume is very compact and well shaped. S800Na is 2-way system, electronic limiter protection. Include one 8 inch mid-bass and one 8 inch coaxial neodymium full range transducer. The coaxial transducer of S800Na is Elder's latest unique design of neodymium transducer. Unique structure of coaxial neodymium transducers combining middle-low and HF range with one single magnetic circuit has effectively solved the phase deviation problem which usually occurs between high frequency and middle-low frequency sections along X.Y and Z axis. The diaphragm is made of specially coated material which decreases the distortion due to unsynchronized vibration of different parts of the suspension system. Sandwich type structure of voice coil, linear symmetrical magnetic circuit and aluminum short loop weakens the speaker's harmonic distortion. Line array clusters of speakers can be set up by connecting rigging points.

SPECIFICATION

Transducers	LF:8"×1 MF:8"×1 HF:φ34mm×1
Frequency Response(-3dB)	80Hz-20kHz
Input Sensitivity	Line 500mV
SPL(1m)	120dB
Max SPL(1m)	126dB
Amplifier Power	200W+50W
Input Impedence	Unbalanced 10k
Range for volume	± 12dB
Dispersion(H×V)	90°×90°
Crossover Point	2kHz
THD	< 3%
Input Connectors	XLR J3P / XLR K3P
Power Supply	AC 115V/230V, 50Hz/60Hz
Net Weight	15kg
Gross Weight	18kg
Dimensions (W×D×H)	265×292×480mm
Packing Dimensions(W×D×H)	353×325×550mm

S800Na

FREQUENCY RESPONSE

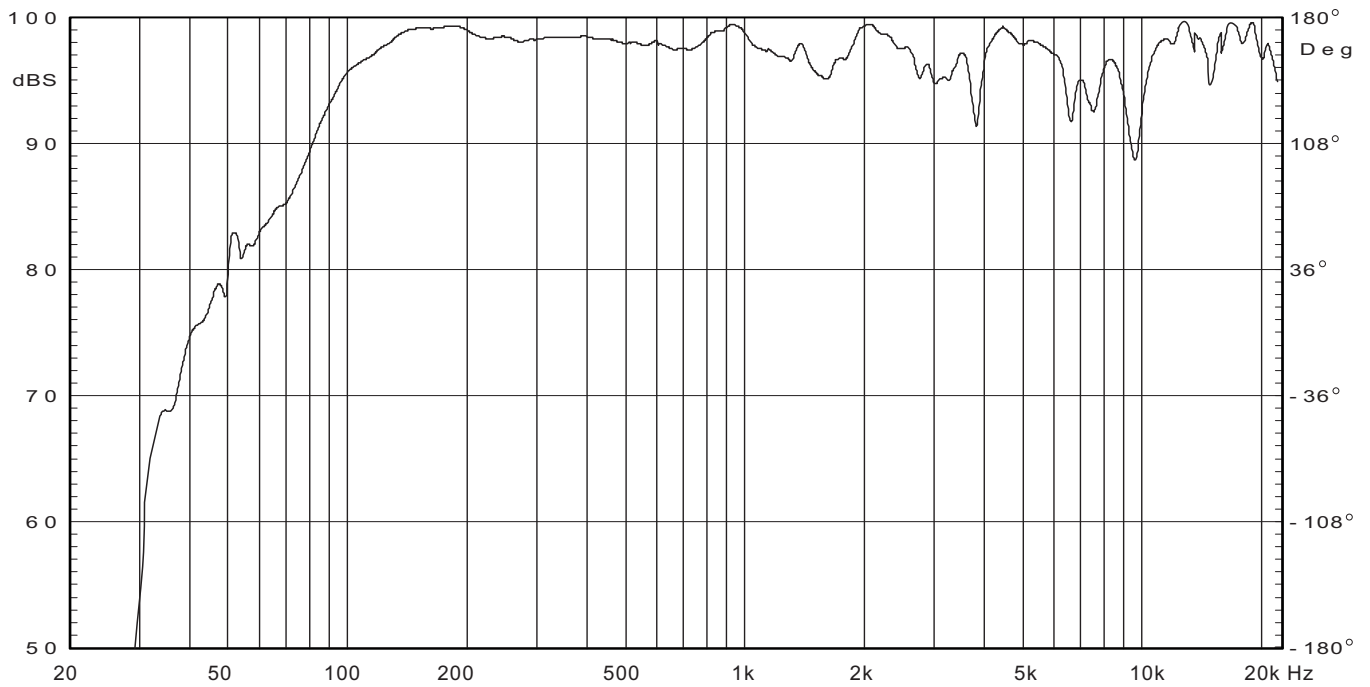

PHASE RESPONSE

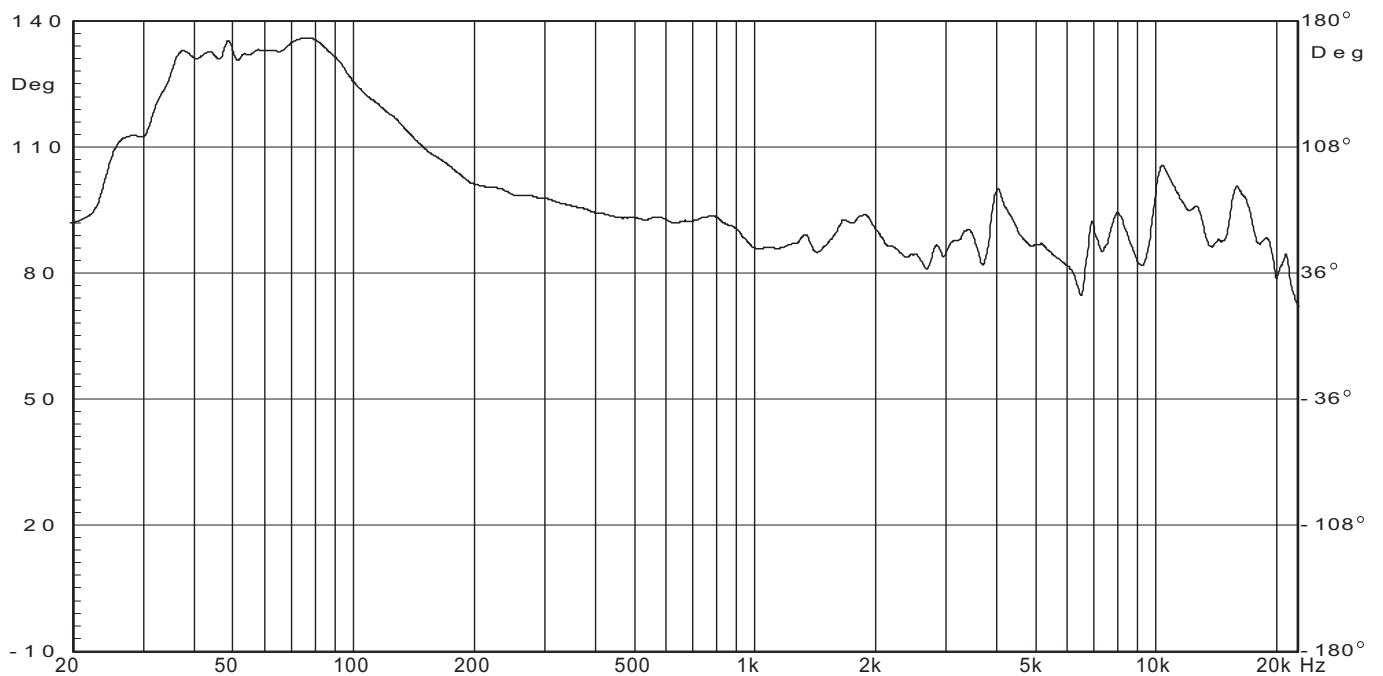

S800Na

WATERFALL

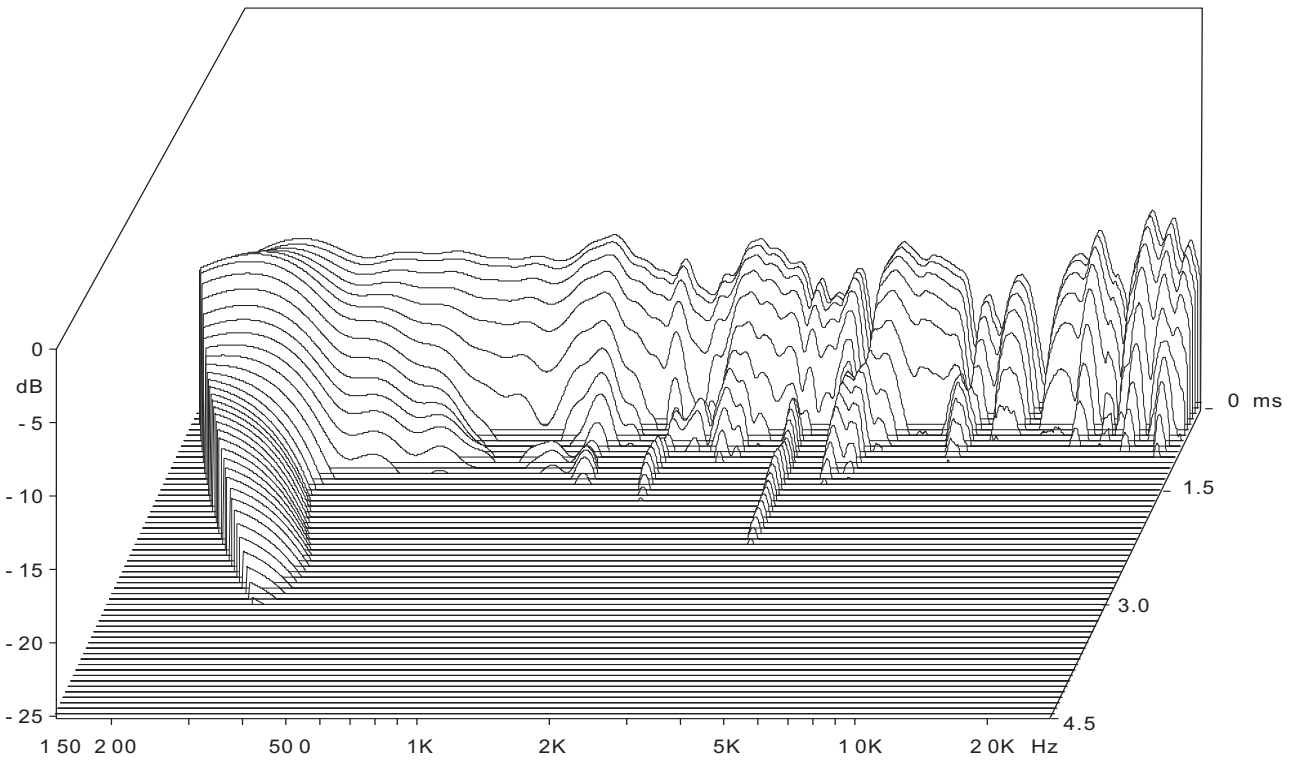

THD

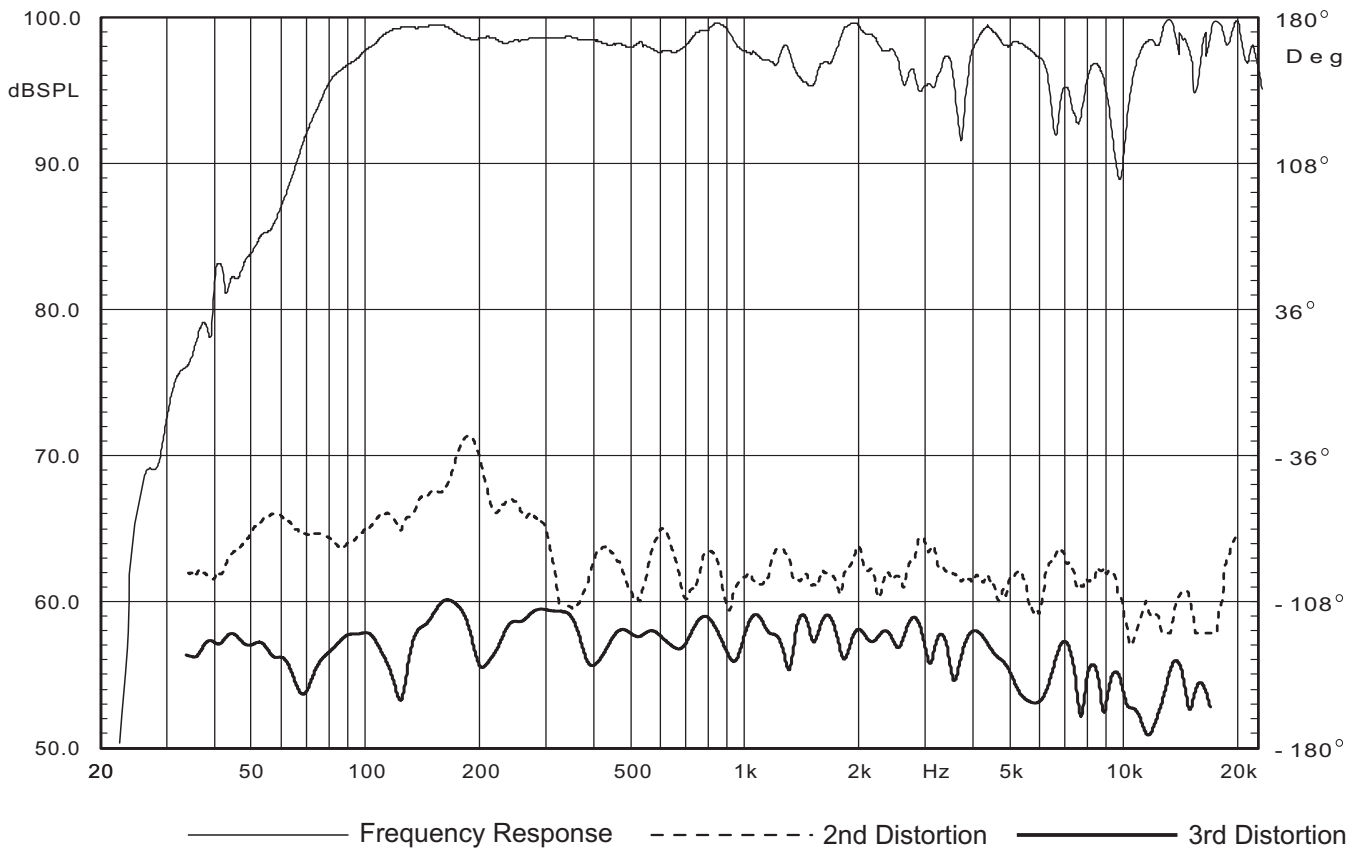

S800Na

HORIZONTAL DIRECTIVITY

The data of S800Na horizontal directivity were collected by testing the speaker system in a big anechoic chamber.

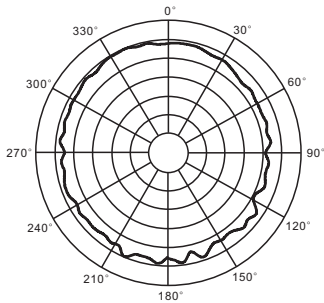

100Hz

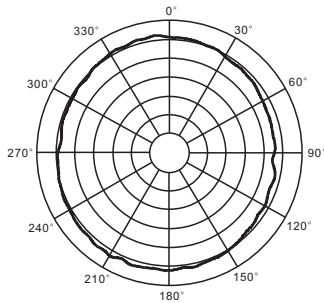

160Hz

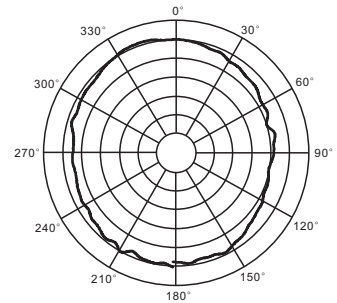

200Hz

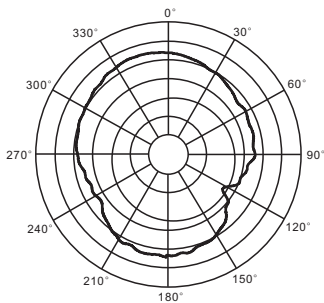

400Hz

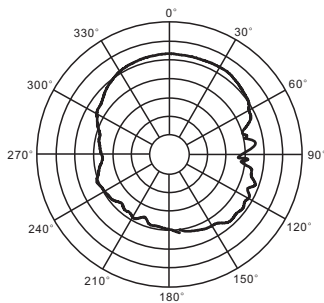

630Hz

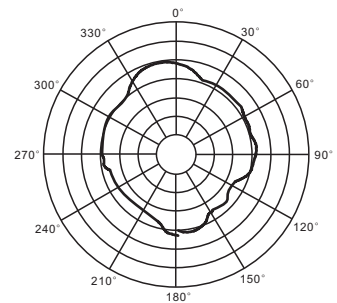

1.0kHz

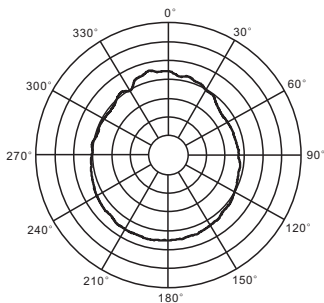

1.6kHz

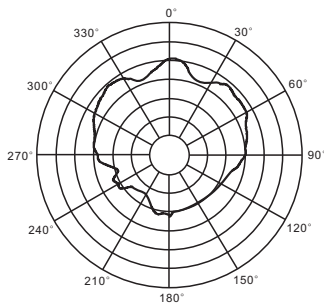

2.5kHz

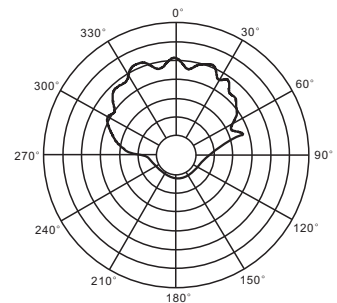

3.15kHz

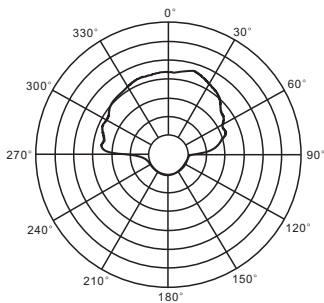

6.3kHz

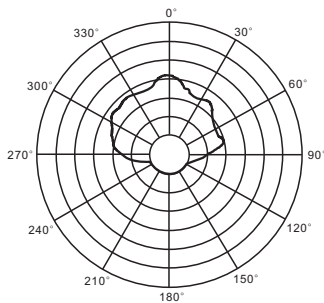

10kHz

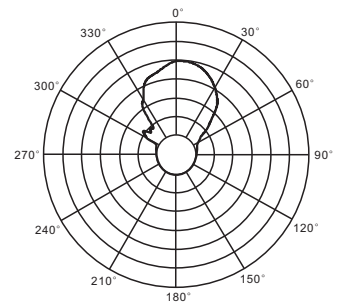

16kHz

The scale is stepped by 6dB increment.

S800Na

VERTICAL DIRECTIVITY

The data of S800Na vertical directivity were collected by testing the speaker system in a big anechoic chamber.

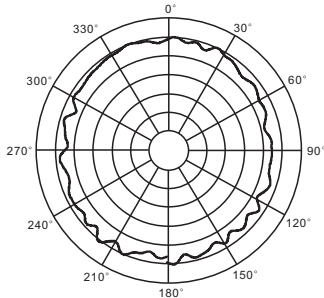

100Hz

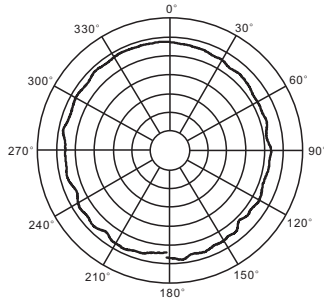

160Hz

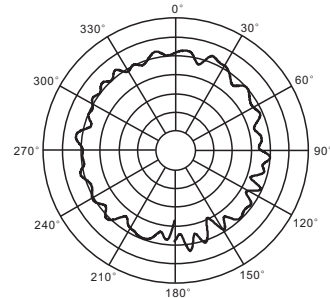

200Hz

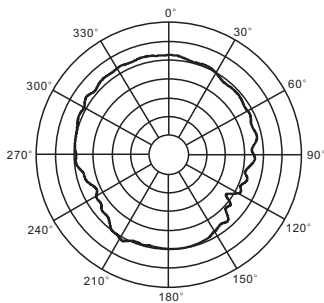

400Hz

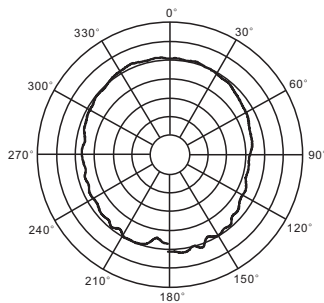

630Hz

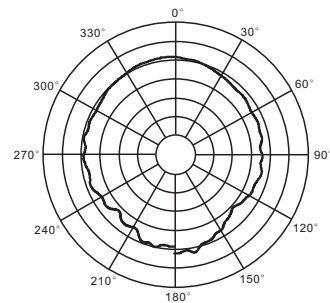

1.0kHz

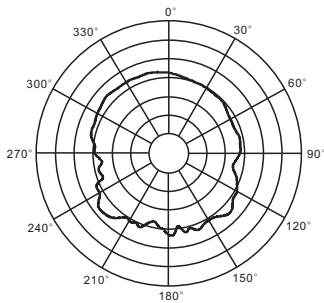

1.6kHz

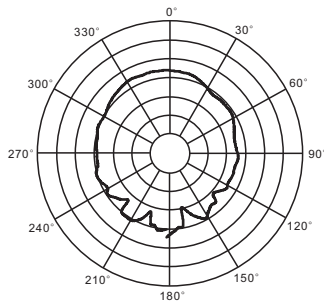

2.5kHz

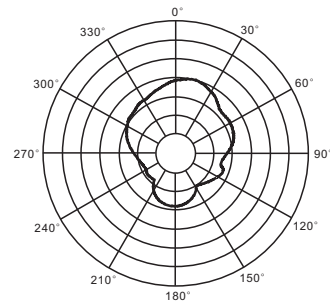

3.15kHz

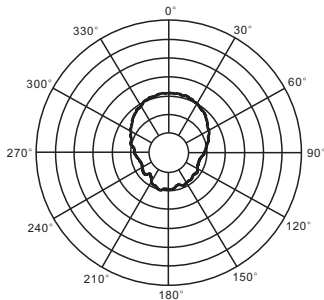

6.3kHz

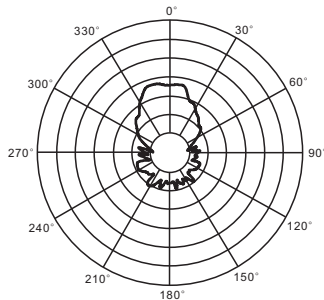

10kHz

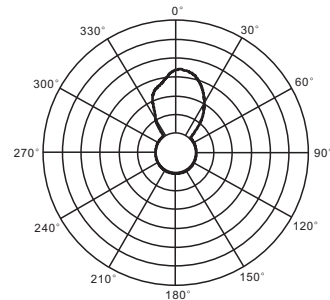

16kHz

The scale is stepped by 6dB increment.

S800Na

AMPLIFICATION MODULE

ACTIVE AMPLIFIER

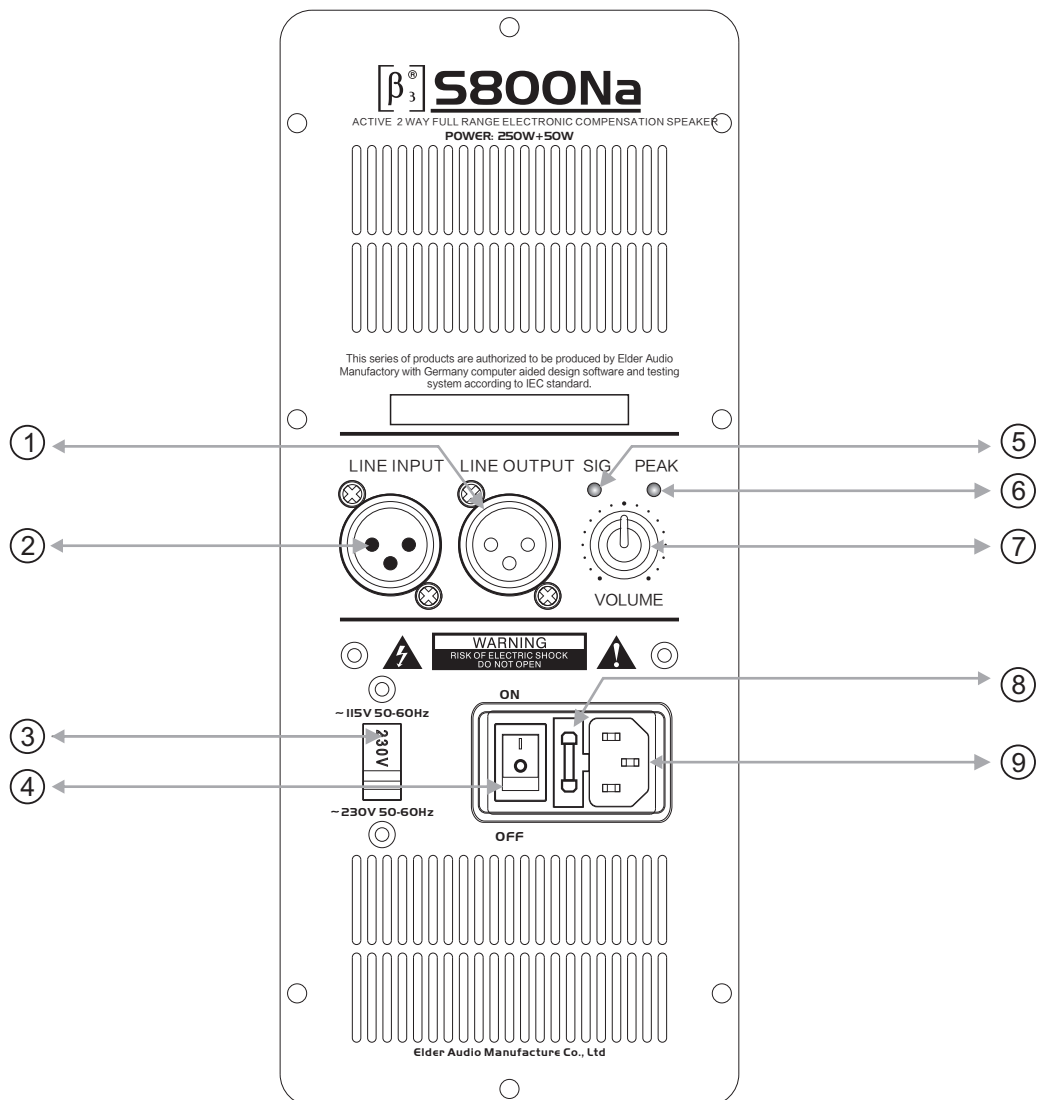

- 1. Line signal output
- 2. Line signal input
- 3. Voltage switch

- 4. Power supply switch
- 5. Line signal indicator
- 6. Overloading indicator

- 7. Volume
- 8. Fuse
- 9. Power supply input

S800Na

INSTALLATION

吊装

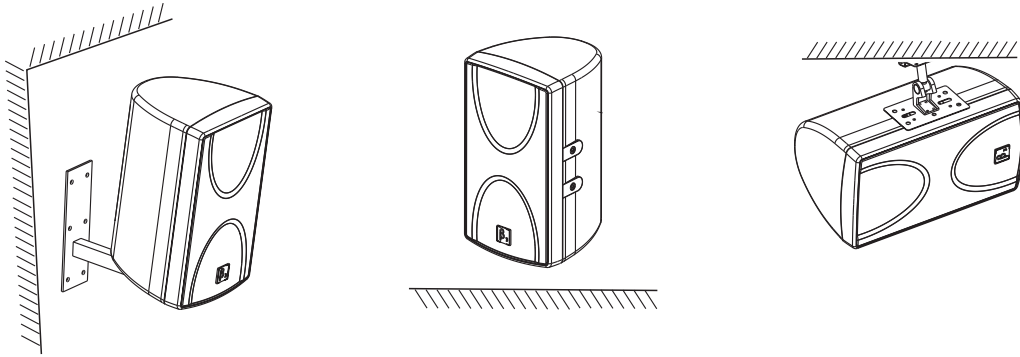

DIMENSIONS

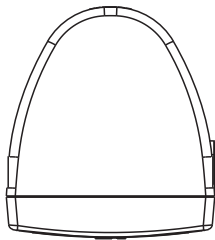

Top view

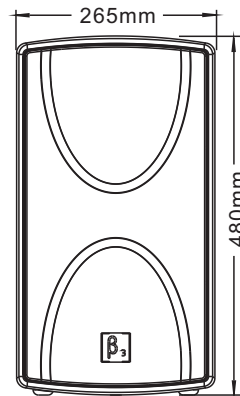

Front view

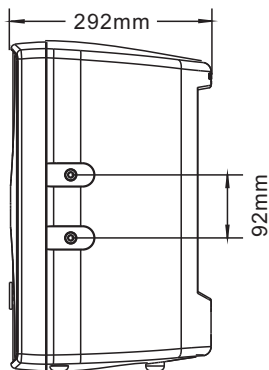

Side view

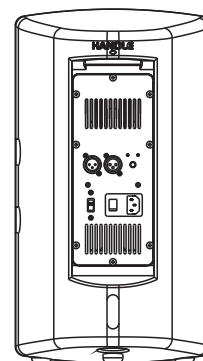

Back view

S800Na

LIMITED WARRANTY

If malfunction occurs during the specified warranty period from the date of original purchase, the product will be repaired or replaced without charge by Elder Audio.

The Limited Warranty does not apply to:

- (a) exterior finish or appearance;
- (b) certain specific items described in the individual product data sheet or owner's manual;
- (c) malfunction resulting from use or operation of the product other than as specified in the individual product data sheet or owner's manual;
- (d) malfunction resulting from misuse or abuse of the product;
- (e) malfunction occurring at any time after repairs have been made to the product by anyone other than Elder Audio Service or any of its authorized service representatives.

To obtain warranty service, customer must deliver proof of purchase of the product in the form of a bill of sale or receipt invoice.

S800Na Speakers and Speaker Systems are guaranteed against malfunction due to defects in materials or workmanship for a period of three (3) years from the date of original purchase. The Limited Warranty does not apply to burned voice coils or malfunctions such as cone and/or coil damage resulting from improperly designed enclosures. Additional details are included in the Limited Warranty statement.

S800Na Accessories are guaranteed against malfunction due to defects in materials or workmanship for a period of one (1) year from the date of original purchase. Additional details are included in the Limited Warranty statement.

S800Na Flying Hardware (including enclosure-mounted hardware and rigging accessories) is guaranteed against malfunction due to defects in materials or workmanship for a period of one (1) year from the date of original purchase. Additional details are included in the Limited Warranty statement.

Specifications are subject to change without notice.



Beta Three
S800Na